

遵守欧盟WEEE和ROHS之规定

"线性"手感

1. 此轴不能过波峰焊

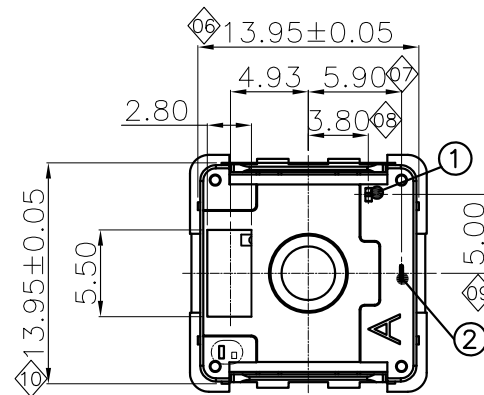
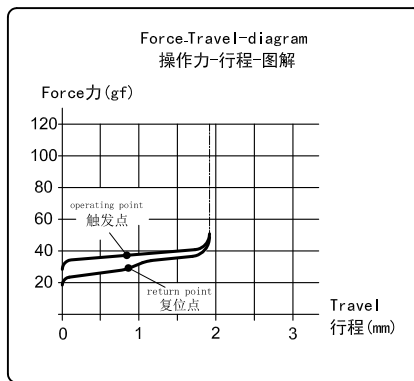
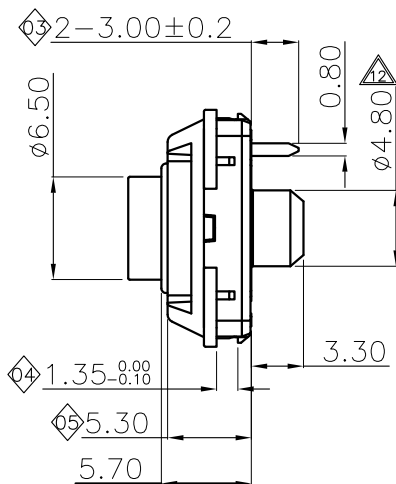
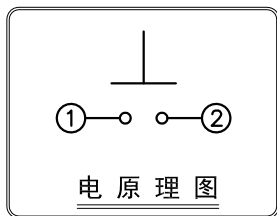
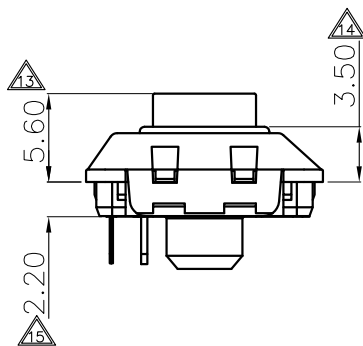
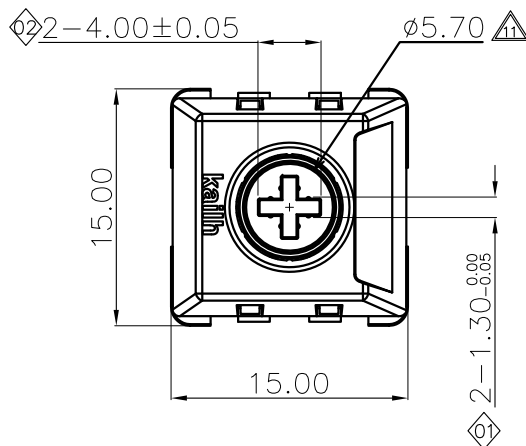

Specification :

1. Rating :12DC 10mA
2. Contact Resistance : 200mΩ Max
3. Insulation Resistance :100MΩ Min (DC100V)
4. Withstand Voltage :AC100V for 1 minute
5. Operation Force :37±10gf
6. Return force: 15gf min
7. Conduction travel:0.8mm±0.30mm
8. Total travel: 1.8+0.3/-0mm
9. Operating Life(Resistance load DC12V 10mA) : 50,000,000 Cycles

备注:

◇：表示重点管控尺寸，首检时需量测。
 △：表示次重点管控尺寸，一般为装配尺寸，首检时需量测。
 1) 重点及次重点管控尺寸中的序号不可重复，需依次往后增加。若其中有某个尺寸在变更或其它状况下，尺寸消失或不要求管控时，原序号不可再用。有其它尺寸需要增加管控时，序号往后增加。
 2) 版次定义:新开发而未转量产之产品图面版次为A1、A2、A3... 已转量产之产品图面版次为A、B、C...，Z以后用AA、AB、AC...

序号	零件	端子编号	用量	材料	镀层/颜色	备注
承认		日期		东莞市凯华电子有限公司 KAIHUA ELECTRONICS CO.,LTD		
设计	李志锋	2024.10.10				
审核	吕攀豪	2025.05.05		名称	PG1353D 线性轴	
核准				料号	CPG1353D01D01-40	
工程变更单号			版次	日期	说明	修改
AO			2024.04.24	NEW	李志锋	吕攀豪
工程变更单号			版次	日期	说明	修改

未注尺寸公差	30<L	±0.30	角度	单位: mm	比例: 1:1	视角
	10<L	±0.20				
	5<L	±0.15				
	L≤5	±0.10	±2'	图号	KHA-PG1353D-*****	页次 1 OF 2

遵守欧盟WEEE和ROHS之规定

"线性"手感
1. 此轴不能过波峰焊

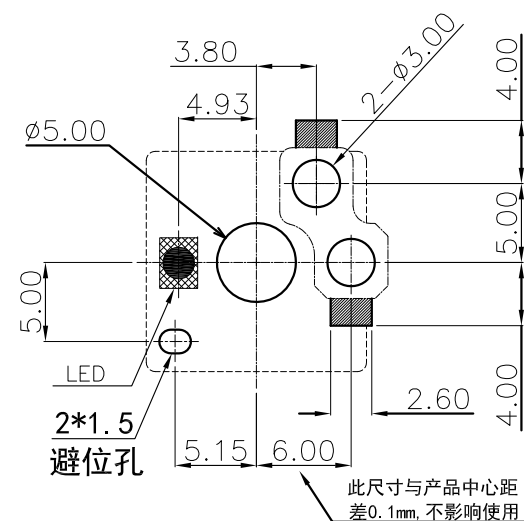
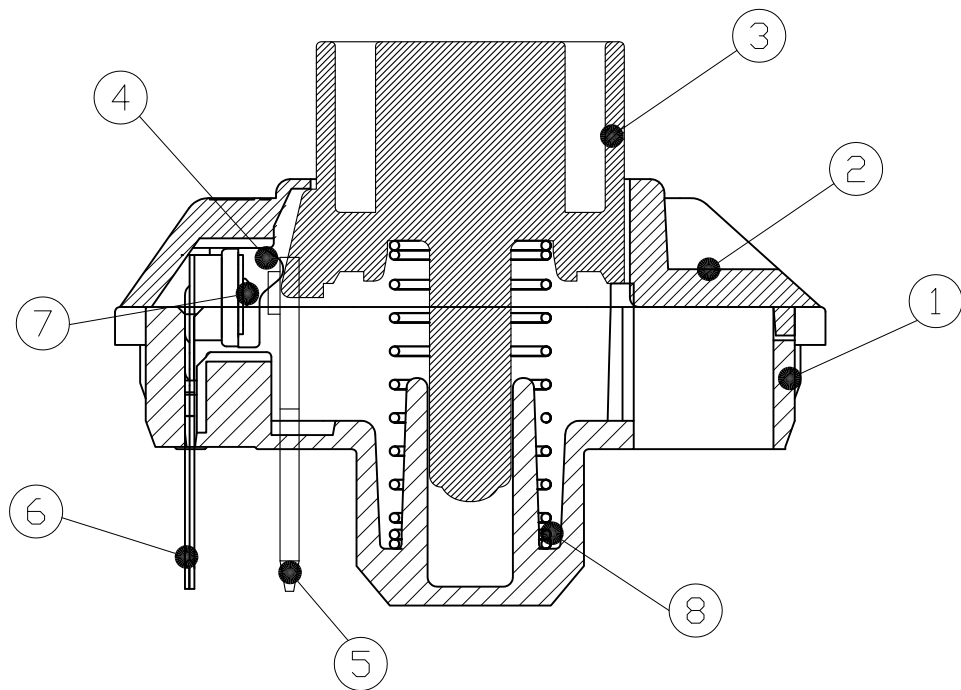

有连接器PCB开孔图
注意 焊盘面视图(供参考)

⑨	Grease	—	—	—	Natural	0.01-0.02g
⑧	Spring	—	1	Stainless Steel	Natural	
⑦	Contact	—	2	Composite materials	Natural	
⑥	Terminal	—	1	Phosphor Bronze	Natural	
⑤	Terminal	—	1	Brass	Sn+Ni	Ni:12-250 ^u Sn:80-1500 ^u
④	Active button	—	1	PA66 G30	Gray	
③	Keystoke	—	1	POM	Light Purple	
②	Cover	—	1	PC	Purple Transparent	
①	Base	—	1	POM	Light Blue	
序号	零件	端子编号	用量	材料	镀层/颜色	备注

承认		日期		 东莞市凯华电子有限公司 KAIHUA ELECTRONICS CO.,LTD			
设计	李志锋	2024.10.10					
审核	吕攀豪	2025.05.05		名称	PG1353D 线性轴		
核准				料号	CPG1353D01D01-40		
未注尺寸公差		30<L	±0.30	角度	单位: mm	比例: 1:1	视角
		10<L	±0.20				
		5<L	±0.15	±2'	图号	KHA-PG1353D-*****	页次 2 OF 2
		L≤5	±0.10				

工程变更单号	版次	日期	说明	修改	审核	核准
	AO	2024.04.24	NEW	李志锋	吕攀豪	

1. General specification 基本事项

- 1.1 Switch action : Push-on type S. P. S. T
开关种类 : 按键开关
- 1.2 Switch rating 额定值 : 12 VAC/DC max. 2 VDC min. 10mA AC/DC max. 10µA DC min.
- 1.3 Operation temperature range 使用温度试验范围 : - 40°C ~ +70°C
- 1.4 Storage temperature range 保存温度范围 : - 40°C ~ + 80°C
- 1.5 Suggested storage period 贮存期限 : about 6 months 最多六个月

Require the tin part on the switch terminals should keep good after storage guarantee date
要求贮存期后开关端子部分上锡仍然良好

1.6 Appearance and dimensions 外形及尺寸 : See outside drawing page 见外形尺寸图

1.7 Standard condition Unless otherwise specified, the test and measurements shall be
试验、测定状态 carried out as follows:

Ambient temperature 温度: 20±2°C

Relative humidity 相对湿度: 45% ~ 85%

Air pressure 气压: 86 ~ 106kPa (860~1060mbar)

However, if doubt arises on the decision based on the measured

Values under the above-mentioned conditions, the following conditions shall be employed:

但是在对判定产生疑义时,按下述状态实施:

Ambient temperature 温度: 20±2°C Relative humidity 相对湿度: 65±5%

Air pressure 气压: 86 ~ 106kPa (860~1060mbar)

2. Performance 性能

2.1 Electrical characteristics 电气性能

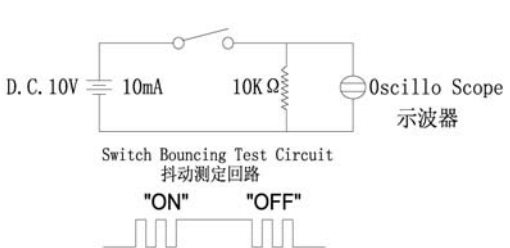
No.	Item 项目	Test condition 试验条件	Performance 规格
2.1.1	Contact resistance 接触电阻	Push force: (Operation force) x 2. 测定时的负荷: 操作方向动作力基准值的2 倍。 Measurement tool : Contact resistance meter 测定器: 微电流接触电阻计(1kHz, 20mV, 5~50mA)	200mΩ MAX 200mΩ 以下
2.1.2	Insulation resistance 绝缘电阻	D. C. 100V (Between terminals) (端子间)	100MΩ min 100MΩ 以上
2.1.3	Withstand voltage 耐电压	A. C100V for 1 min (Between terminals) (端子间)	No. insulation destruction. 无绝缘破坏.
2.1.4	Bouncing 触点抖动	Operation speed : 3~4 times/s 操作速度: 每秒3~4 次 Oscillo scope 示波器 Switch Bouncing Test Circuit 抖动测定回路 	ON: 5ms max 以下 OFF: 5ms max 以下

2.2 Mechanical Characteristics 机械性能

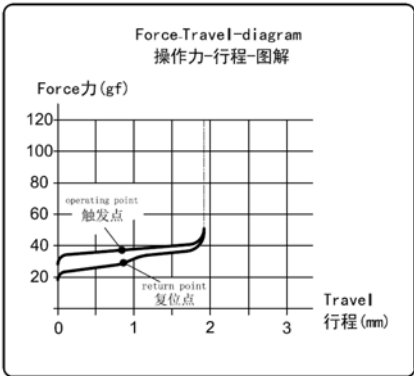
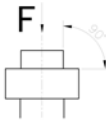
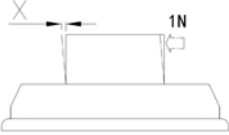
No.	Item 项目	Test condition 试验条件	Performance 规格
2.2.1	Operation force 动作力 Travel to closure 动作行程(见图表)		operating force (动作力) 37±10gf Return force (回弹力): 15gf min Full Travel 全行程 : 1.8mm+0.3/-0 Pre Travel 导通行程 : 0.8mm±0.30
2.2.2	Push strength 按压强度	30N (3Kgf) for 15 sec 30N (3Kgf) 15 秒 	No damage (Electrical and mechanical) 无异常(电气、机械性能)
2.2.3	Pull strength 推压强度	Break by drawing push plate in the direction of right diagram 抽拔推杆使其破坏的强度.	30N min (3kgf min)
2.2.4	Vibration test 耐振性	1) Amplitude 全振幅: 1.5 mm 2) Sweep rate: 10-55-10HZ for 1 minute 扫描速度: 10-55-10HZ 1 分钟 3) Sweep method: Logarithmic frequency sweep rate 扫描方式: 对数频率扫描速度 4) Vibration direction: X, Y, Z (3 directions) 振动方向: X, Y, Z (3 方向) 5) Time: Each direction 2 hours (Total 6 hours) 时间: 每个方向2 个小时(共6 个小时)	No. 2.1 and 2.2.1 to 2.2.2 shall be satisfied 满足2.1 项和2.2.1 至 2.2.2 项.
2.2.5	Wobbling of Button 按钮摇摆偏移	Apply 1N force as shown below 在按钮侧臂施加1N的力测量其最大偏移尺寸(横向纵向). 	Displacement 0.35mm Max 开关按钮最大偏移尺寸为0.35mm



2.3 Climatic characteristics 耐候性能

No.	Item 项目	Test condition 试验条件	Performance 规格															
2.3.1	Cold test 耐寒性	1) Temperature : $-40\pm 2^{\circ}\text{C}$ 温度: $-40\pm 2^{\circ}\text{C}$ 2) Duration of test: 48h 持续时间: 48 小时 3) Take off a drop water 去掉水珠 4) Standard conditions after test : 1h 试验后的放置条件: 1 小时	Contact resistance 200mΩ max No. 2.1.2 to 2.1.4 and No. 2.2.1 to 2.2.2 shall Be satisfied 接触电阻 200mΩ 以下 满足2.1.2 到2.1.4 项、 2.2.1 到2.2.2 项.															
2.3.2	Heat test 耐热性	1) Temperature : $70\pm 2^{\circ}\text{C}$ 温度: $70\pm 2^{\circ}\text{C}$ 2) Duration of test: 48h 持续时间: 48 小时 3) Standard conditions after test : 1h 试验后的放置条件: 1 小时	Contact resistance 200mΩ max No. 2.1.2 to 2.1.4 and No. 2.2.1 to 2.2.2 shall Be satisfied 接触电阻 200mΩ 以下 满足2.1.2 到2.1.4 项、2.2.1 到 2.2.2 项.															
2.3.3	Temperature cycle 温度循环	1) Test cycles :20 cycles 试验周期: 20 个周期 2) Standard condition after test :1h 试验后的放置条件: 1 小时 <table border="1" data-bbox="555 1272 1150 1579"> <thead> <tr> <th></th> <th>temperature 温度</th> <th>duration of test 持续时间</th> </tr> </thead> <tbody> <tr> <td>1 cycle 一次 循环</td> <td>$20\pm 5^{\circ}\text{C}$</td> <td>1h</td> </tr> <tr> <td></td> <td>$-40\pm 2^{\circ}\text{C}$</td> <td>1h</td> </tr> <tr> <td></td> <td>$20\pm 5^{\circ}\text{C}$</td> <td>1h</td> </tr> <tr> <td></td> <td>$60\pm 5^{\circ}\text{C}$</td> <td>1h</td> </tr> </tbody> </table>		temperature 温度	duration of test 持续时间	1 cycle 一次 循环	$20\pm 5^{\circ}\text{C}$	1h		$-40\pm 2^{\circ}\text{C}$	1h		$20\pm 5^{\circ}\text{C}$	1h		$60\pm 5^{\circ}\text{C}$	1h	Contact resistance 200mΩ max No. 2.1.2 to 2.1.4 and No. 2.2.1 to 2.2.2 shall be satisfied 接触电阻 200mΩ 以下 满足2.1.2 到2.1.4 项、 2.2.1 到2.2.2 项.
	temperature 温度	duration of test 持续时间																
1 cycle 一次 循环	$20\pm 5^{\circ}\text{C}$	1h																
	$-40\pm 2^{\circ}\text{C}$	1h																
	$20\pm 5^{\circ}\text{C}$	1h																
	$60\pm 5^{\circ}\text{C}$	1h																
2.3.4	Humidity test 耐湿性	1) Temperature : $70\pm 2^{\circ}\text{C}$ 温度: $70\pm 2^{\circ}\text{C}$ 2) relative humidity: 90~95% 相对湿度: 90~95% 3) Duration of test: 96h 持续时间: 96 小时 3) Take off a drop water 去掉水珠 5) Standard conditions after test : 1h 试验后的放置条件: 1 小时	Contact resistance 200mΩ max No. 2.1.2 to 2.1.4 and No. 2.2.1 to 2.2.2 shall Be satisfied 接触电阻 200mΩ 以下 满足2.1.2 到2.1.4 项、 2.2.1 到2.2.2 项.															



No.	Item 项目	Test condition 试验条件	Performance 规格
2.3.5	Endurance (switching action) 耐久特性 (开关寿命)	1) D.C. 12V 10mA resistance load D.C 12V 10mA 电阻负荷 2) Operation speed :10 times / s 动作速度: 10 次/ 秒 3) Push force : 250gf±50gf (spring) 按力: 250gf±50gf (弹簧) 4) Operation number :50, 000, 000cycles 动作次数:50, 000, 000次	Contact resistance 1Ω max 接触电阻 1Ω 以下 Bouncing: 10 ms max 触点抖动: 10 毫秒以下 Variation rate of operation force shall be within ±30%to the value before testing 动作力的变化范围在初始值的±30% 以内 No. 2. 1. 2 and 2. 2. 2 shall Be satisfied 满足2. 1. 2 和2. 2. 2 项
2.3.6	盐雾实验 Salt Mist Test	试件在下述实验后测量: 1. 温度: 35±5°C 2. 盐溶液浓度: 5±1% (质量百分比), 3. 试验时间: 24±0.5 小时, 4. 试验后, 将盐沉积物用水冲掉。 The switch shall be checked after following test: 1. Temperature: 35±5°C 2. Salt solution: 5±1% (Solids by mass) 3. Duration: 24±0.5 hours, 4. After immersing, salt deposit shall be removed by running water.	Contact resistance 200mΩ max No. 2. 1. 2 to 2. 1. 4 and No. 2. 2. 1 to 2. 2. 2 shall Be satisfied 接触电阻 200mΩ 以下 满足2. 1. 2 到2. 1. 4 项、2. 2. 1 到 2. 2. 2 项.
2.3.7	Shock 耐冲击性	Measure after test at a condition below 在下列条件下进行测试后的量度 Peak acceleration:80G 冲击加速度:80G Test time-6direction , each 3 times total 18 times 测试次数-6 个方向, 各3 次共计18 次。	No. 2. 1 and 2. 2. 1 to 2. 2. 2 shall be satisfied 第2. 1 及2. 2. 1—2. 2. 2 都应符合要求

3. Acoustic Noise 噪音测试

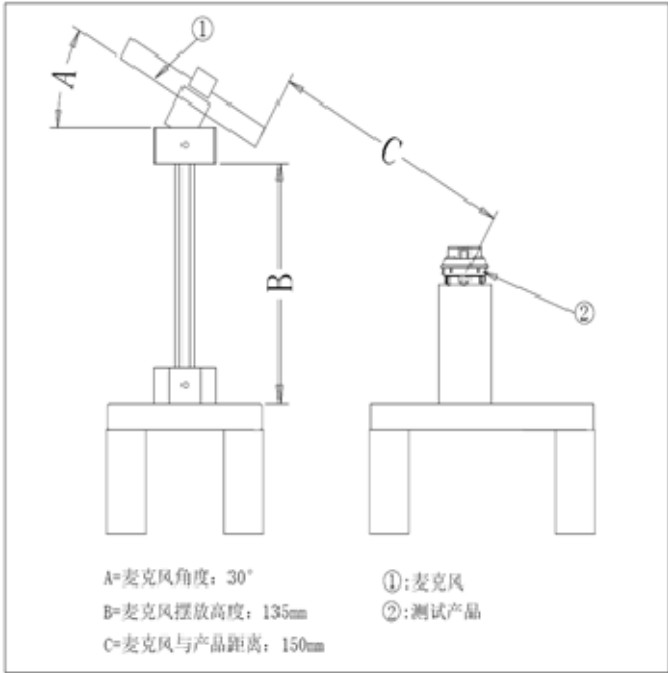
No.	Item 项目	Test condition 试验条件	Performance 规格
3.1.1	Acoustic Noise 噪音测试	<p>Background Noise: 10dB Max. 背景噪音最大: 10dB Max</p> <p>手指按压 Pressing by fingers</p> <p>Sound Level Meter Position 声纳计摆放位置</p> <p>1) Distance 距离 (C) : 150 mm</p> <p>2) Vertical 高度 (B) : 135mm</p> <p>3) Angle 角度 (A) : 30 deg</p> <p>Drop Height 开关按压行程: 1.5mm</p> <p>Operation speed 按压频率: 1次/秒</p> <div data-bbox="466 1072 1136 1742" style="border: 1px solid black; padding: 10px; margin-top: 20px;">  <p>A=麦克风角度: 30° ①: 麦克风 B=麦克风摆放高度: 135mm ②: 测试产品 C=麦克风与产品距离: 150mm</p> </div>	下压最大噪音: 35 dB Maximum sound while pressing: 35dB



4. Precaution 注意事项

4.1 Note(注意点)

1) Please be cautious not to give excessive static load or shock to switches.

注意不要施加超负荷的压力或晃动开关.

2) Preservation under high temperature and high humidity or corrosive gas should be avoided especially. When you need to preserve for a long period, do not open the carton.

保管时尤其应注意避开高湿高温和有腐蚀性气体的环境. 如需长时间保存, 请不要打开包装箱.

3) Panasert RH and RH6 shall be used as the standard insert machine (use N type clinch).

使用标准插入机器PANASERT 和RH6 (使用N 式钉)

4) CONTROL HAZARDOUS SUBSTANCE: THE PRODUCT SHOULD BE MEET ROHS SPECIFICATION.

产品应满足 ROHS 环境管理物质管制标准

力和行程说明 The explanation for force and travel:

动作力 Operation Force: 导通位置的力. The pressing force while conduction

触感力 Tactile Force: 从自由位置到导通过程中所需要的最大力. The maximum force in the pressing from free position to conduction

回弹力 Return force: 从全行程位置到复位位置过程中的最小力. The minimum force from the position of full travel to original position

导通行程 Conduction travel: 从自由位置到导通位置的距离. The distance from free position to conduction position

全行程 Total travel: 从自由位置到触底位置的距离. The distance from free position to bottom position